

Industrial Damper • Straight Blades • Formed Channel Frame • Galvanized Steel • 250°F Max Temperature

Standard Construction and Materials

- FRAME:** 2" x 8" x 2" - 14 GA. galvanized steel, formed channel.
- BLADE:** 16 GA. formed galvanized steel, approximately 6" on centers.
- SHAFT:** 3/4" dia. plated, cold-finished steel stub. Plug welded to blade.
Drive shaft to be continuous length.
- BEARINGS:** Stainless steel flanged sleeve, press fit into frame.
- LINKAGE:** Plated steel arm located in jamb. 1/2" dia. inter-connecting rod with stainless steel trunnion pivot fastener.
- OPERATOR:** Extended shaft only.
- FINISH:** Mill.

TEMP. LIMIT: 250°F. Consult the factory for temperatures above 250°F.

Options

- Blade Edge Seals - Stainless steel.
- Stuffing boxes and replaceable packing.
- Flanges other than 2" wide.
- Perimeter holes - One flange or two flanges.
- Finishes - Acrylic, baked enamel, etc.
- Materials - Stainless steel, extruded aluminum, galvanized steel, etc.

Notes

1. 1/4" nominal deduction will be made to the opening size given.
2. Dampers 36" wide and above, furnished with blade and/or jamb seals, shall be provided with double jamb linkage.
3. Construction may be with other materials when required to meet special conditions, such as: temperature, pressure, velocity, system environment, or other specifications.
4. Approximate shipping weight is 8.0 lbs./sq.ft.

Damper Sizes

Min. Size	Max. Size
6"W x 6 3/4"H (Single Blade)	48"W x 96"H
6"W x 12" (Opposed)	

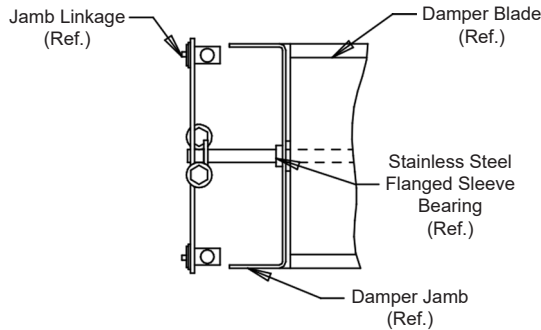

Jamb Linkage Detail
Opposed linkage shown.

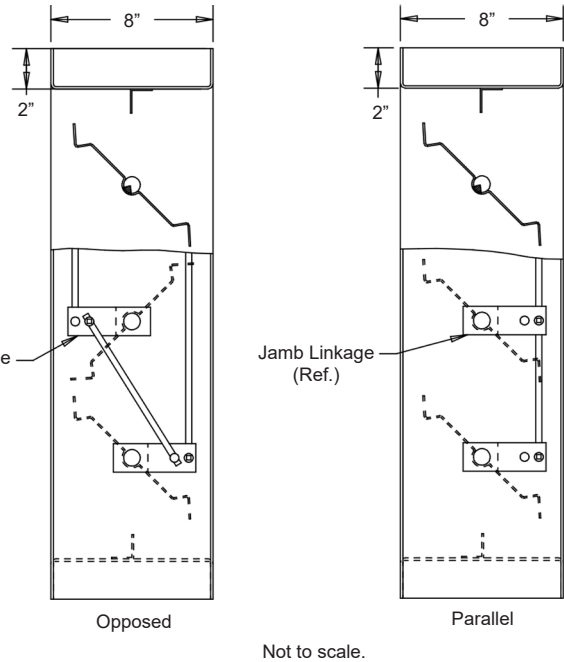
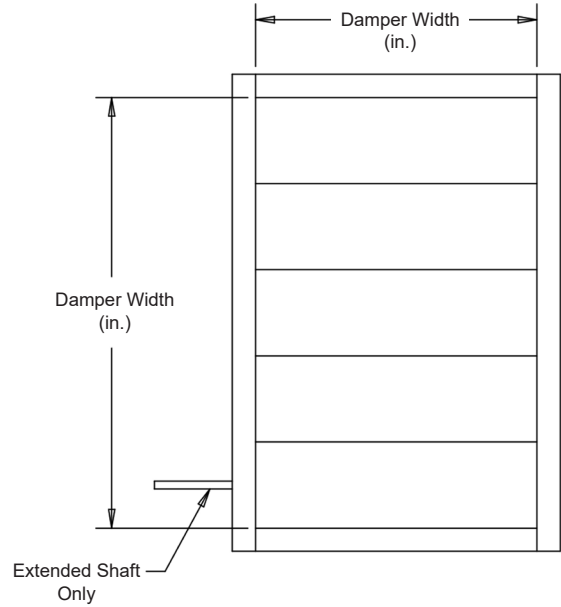

Item #	Qty	Damper Size		Parallel Blades	Opposed Blades	Seals	Actuator Model	Interior	Exterior	N.C.	N.O.	Union Made
		Width	Height					Act. Location		Function		
Arch. / Eng.:						EDR:		ECN:		Job:		
Contractor:												
Project:						Date:		DWN:		DWG:		

In the interest of product development, CESCO Products reserves the right to make changes without notice.



450 Riverside Dr • Wyalusing PA, 18853
 Phone: 570-746-1888 • Fax: 570-746-9286
 www.cescoproducts.com

Industrial Damper • Straight Blades • Formed Channel Frame • Galvanized Steel • 250°F Max Temperature

Pressure Drop Data

Pressure drop ratings are based on AMCA Standard 500, using test set-up figure 5.3 and figure 5.5. Static pressures are corrected to .075 lb./cu.ft. air density.

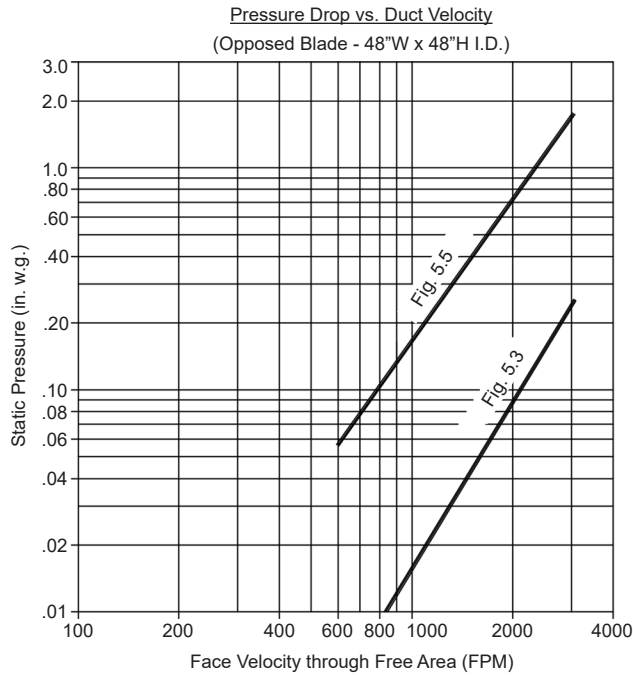

Air Leakage Data

Air leakage quantities shown in the chart are results of tests per AMCA Standard 500 and are shown at 1 in. w.g. differential pressure and are corrected to .075 lb./cu.ft. air density.

Air Leakage (Total CFM)

		Damper Width (in. I.D.)						
		12"	18"	24"	30"	36"	42"	48"
Damper Height (in. I.D.)	12"	4	6	8	10	12	14	16
	24"	8	12	16	20	24	28	32
	36"	12	18	24	30	36	42	48
	48"	16	24	32	40	48	56	64
	60"	20	30	40	50	60	70	80
	72"	24	36	48	60	72	84	96
	84"	28	42	56	70	84	98	112
	96"	32	48	64	80	96	112	128

For determining leakage values greater than 1 in. w.g. to a maximum of 20 in. w.g., use the multiplier correction chart below.

Static Pressure (in.)	1	2	3	4	5	6	7	8	9	10	11	12	13	14	15	16	17	18	19	20	Damper Width (in.)	
Multiplier Correction Factor	3.0	4.5	5.5	6.5	7.0	7.8	8.3	9.0	9.7	10.2	10.5	11.3	11.6	12.0	12.5	12.9	13.3	13.6	14.3	14.6	12 - 17	
	2.0	3.0	3.5	4.2	4.5	5.0	5.5	6.0	6.2	6.8	7.0	7.5	7.7	7.8	8.2	-	-	-	-	-	-	18 - 24
	1.0	1.5	1.8	2.1	2.3	2.6	2.8	3.0	3.2	3.4	-	-	-	-	-	-	-	-	-	-	-	24 - 36
	1.0	1.5	1.8	2.1	2.3	2.6	2.8	-	-	-	-	-	-	-	-	-	-	-	-	-	-	36 - 48

Air leakage ratings are based on AMCA Standard 500, using test set-up Fig. 5.4 with a damper closing torque applied to the damper of 10 in. lbs./sq.ft. of damper face area for a 48" x 96", with a minimum of 40 in. lbs./sq.ft. of a damper area for a size 48" x 6¾".

Damper air leakage shown is based on dampers furnished with blade and jamb seals. Results published are for the model PC34 industrial damper for a range of damper sizes.